



GYPMR

Magnetostrictive Cylinder Sensor 50-2000 mm

GYPMR sensor has been developed as the most compact magnetostrictive sensor, offering the same header dimensions as the other Regasense brand sensors.

Adopting Piezo detecting system inside the sensor head, it has two main advantages; short dead zone (8 mm) and no influence of magnetic field upon the sensor head.

With the external controller, that can be placed up to 20 meters from the sensor, a robust sensor system can be achieved.

The magnetostrictive sensors in the GY-series are produced by leading sensor manufacturer Santest. Decades of experience guarantee the highest quality.

Magnetostrictive sensors are "non-contact" with excellent accuracy, reliability and life time.

- Compact design
- Short dead-zone
- Non-contact technology
- Custom stroke lengths



Electrical Connection	
Power Supply	24 VDC ±2

Signal Specification	
Output Voltage	0-10 V (load min. 2kΩ)
Output Current	4-20 mA (load max. 500Ω)
Linearity	< ±0.05% FS
Resolution	0.01% FS
Repeatability	< ±0.01% FS
Sampling Frequency	1 kHz
Stroke Lengths	50-2000 mm
Temperature Drift Sensor	< ±45 ppm FS/°C
Temperature Drift Controller	< ±15 ppm FS/°C

Operating Condition	
Operating Temperature Sensor	-20°C...+80°C
Operating Temperature Controller	0°C...+60°C
Temperature Storage	-40°C...+80°C
Operating Pressure	350 Bar
Vibrations	6G (or 40 Hz 2mmPP)
Shock	20G (2 ms)
IP Grade	IP67 (sensor)

Material	
Sensor	Stainless Steel
Magnet MG178	Brass
Cable Jacket	PVC

GYPMR

Magnetostrictive Cylinder Sensor 50-2000 mm

Sensor Probe Dimensions

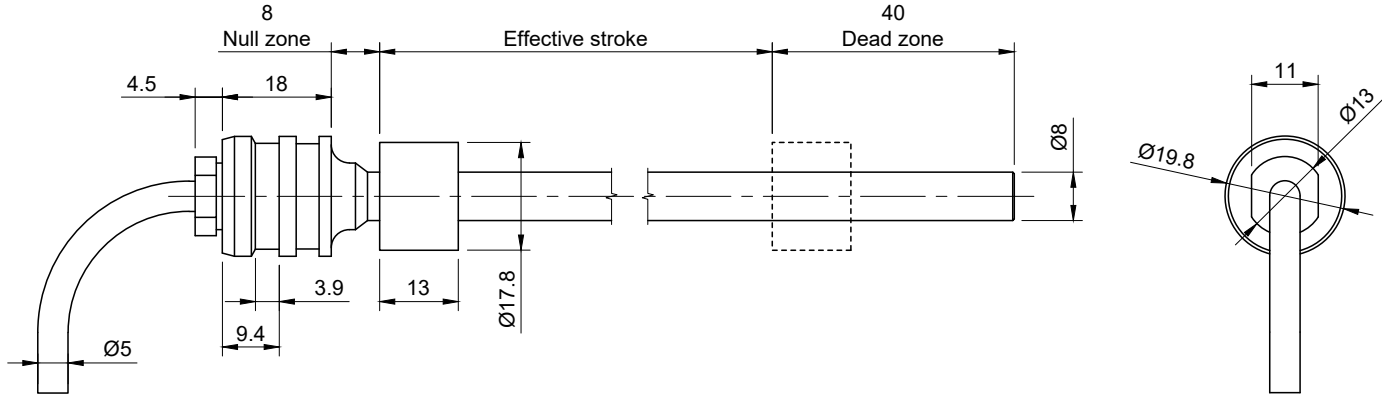

Exploded View (accessories included)

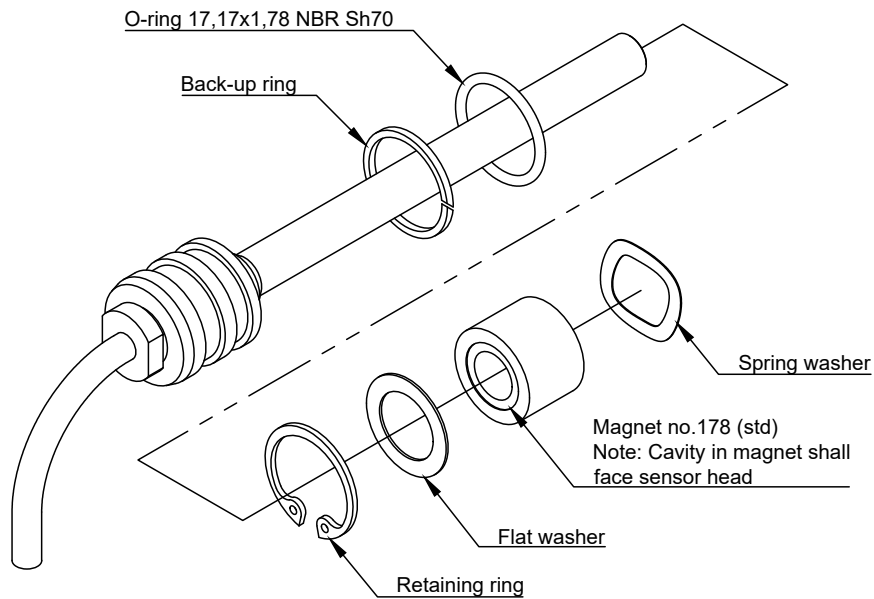

GYPMR

Magnetostrictive Cylinder Sensor 50-2000 mm

Recommended Installation of Sensor Head and Magnet

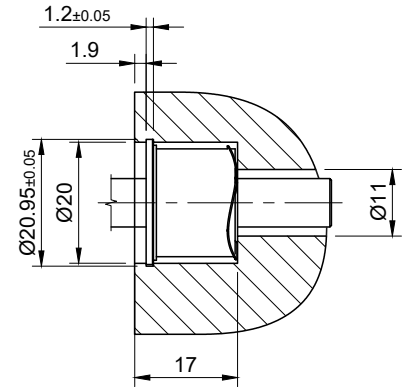
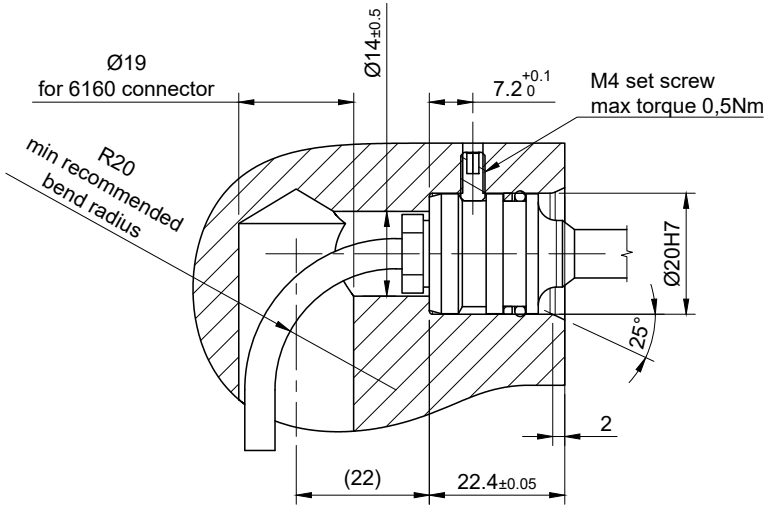

Sensor Magnet No. 178 (std)

Connection Controller

The controller is pre-calibrated for the specific sensor stroke length and specified output configuration. It mounts to a DIN rail and can be installed up to 20 m from the sensor (cable length).

For sensor probes installed in a cylinder, feed the sensor cable through a suitable cable gland that offers good strain relief and ingress protection.

An alternative option is to connect the sensor leads to our 6160 or 6140 M12 connector which mounts directly to the cylinder body.

Note that the shield of the sensor cable is connected to sensor chassis.

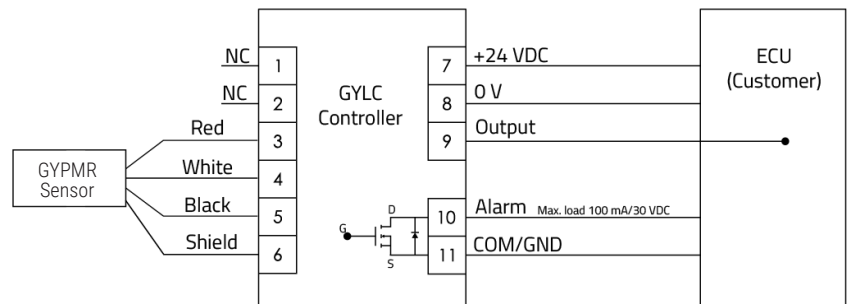
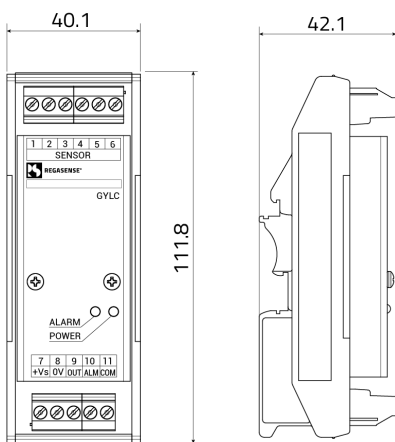

GYPMR

Magnetostrictive Cylinder Sensor 50-2000 mm

Connectors

6160 (M12)

6160 is a flange connector that do not require soldering. The connector is IP67 and supplied with pins mounted on the sensor cable from factory.

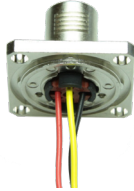

6140 (M12)

6140 is a hermetic glass-to-metal seal and pressure proof flange connector. The wires are soldered to the connector after the sensor is mounted in the cylinder.

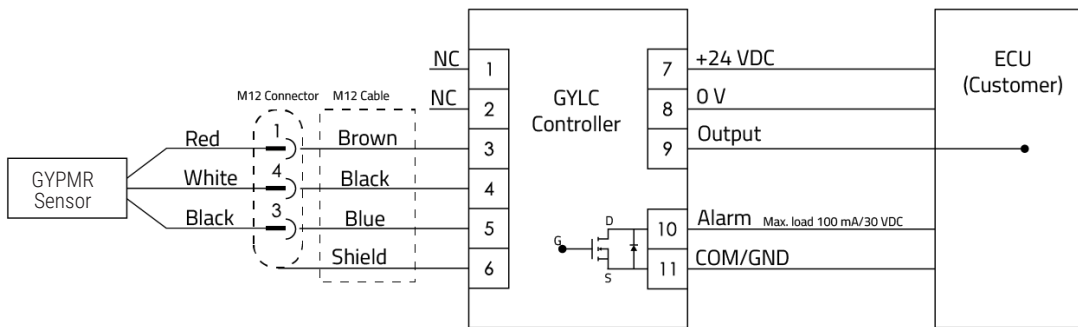

For more information about cylinder connectors 6160 and 6140, read respective datasheet.

GYPMR

Magnetostrictive Cylinder Sensor 50-2000 mm

Order Information **Sensor**

GYPMR-0000-8/00-P8-0000-G0F-00

1 2 3 4 5 6 7

1	STROKE LENGTH	15-2000 mm
2	HEAD DEAD ZONE	8 mm (std)
3	TIP DEAD ZONE	40 mm = MG178 (std) 70 mm = MG178, M2PN, M11N 100 mm = T144, T163
4	ROD DIAMETER	P8 = Ø8 mm (std)
5	ASSOCIATED MAGNET	MG178 = No.178 (std) M2PN = No.2PN (≤ stroke 1000 mm) M11N = No.11N (≤ stroke 1000 mm) T144 = No.T14-M4 T163 = No.T16-M3
6	CABLE LENGTH	GxF = Cable x = Cable length in meters, max. 10 m
7	OUTPUT	00 - Depends on external controller

Example: GYPMR-0750-8/40-P8-MG178-G1F-00

Order Information **Controller**

GYLC-0000-00

1 2+3

1	STROKE LENGTH	50-2000 mm
2	OUTPUT	A = 0-10 V B = 4-20 mA
3	DIRECTION OF OUTPUT	D = Increasing (header to tip) R = Decreasing (header to tip)

Example: GYLC-0750-AD